

Automotive regulator

Low Quiescent Current LDO Regulator



BD4xxM5 series

TENTATIVE

DESIGN INFORMATION

●General Description

The BD4xxM5 series are low quiescent regulators featuring 45V absolute maximum voltage, and output voltage accuracy of $\pm 2\%$ (3.3V or 5V:Typ.), 500mA output current and 40 μ A (Typ.) current consumption. These regulators are therefore ideal for applications requiring a direct connection to the battery and a low current consumption. A logical "HIGH" at the CTL pin enables the device (Only W: Includes switch). Ceramic capacitors can be used for compensation of the output capacitor phase. Furthermore, these ICs also feature overcurrent protection to protect the device from damage caused by short-circuiting and an integrated thermal shutdown to protect the device from overheating at overload conditions.

●Features

- Low quiescent current: 40 μ A (Typ.)
- Output current capability: 500mA
- Output voltage: 3.3V or 5V(Typ.)
- High output voltage accuracy: $\pm 2\%$
- Low saturation voltage by using PMOS output transistor.
- Enable Input: a logical "HIGH" at the CTL pin enables the device (Only W: Includes switch)
- Integrated overcurrent protection to protect the IC from damage caused by output short-circuiting.
- Integrated thermal shutdown to protect the IC from overheating at overload conditions.
- Low ESR ceramic capacitor can be used as output capacitor.
- TO252-J5F, TO263-5F, TO252-3, TO263-3F, package

●Key specifications

- Low quiescent current 40 μ A (Typ.)
- Output voltage 3.3V or 5V (Typ.)
- Output current capability 500mA
- High output voltage accuracy $\pm 2\%$
- Enable Input (Only W: Includes switch)
- Low ESR ceramic capacitor can be used as output capacitor
- AEC-Q100 Qualified

●Packages

- WFPJ: TO252-J5F 6.60mm \times 10.10mm \times 2.38mm
- WFP2: TO263-5F 15.10mm \times 10.16mm \times 4.57mm
- FP: TO252-3 6.50mm \times 9.50mm \times 2.50mm
- FP2: TO263-3F 15.10mm \times 10.16mm \times 4.57mm

Figure 1. Package outlook

●Applications

- Automotive (body, audio system, navigation system, etc.)

●Typical Application Circuits

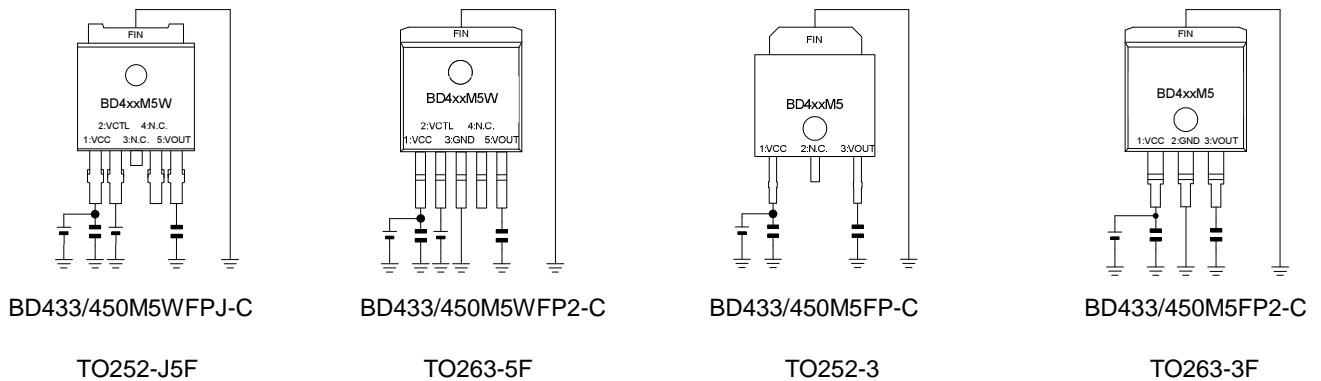
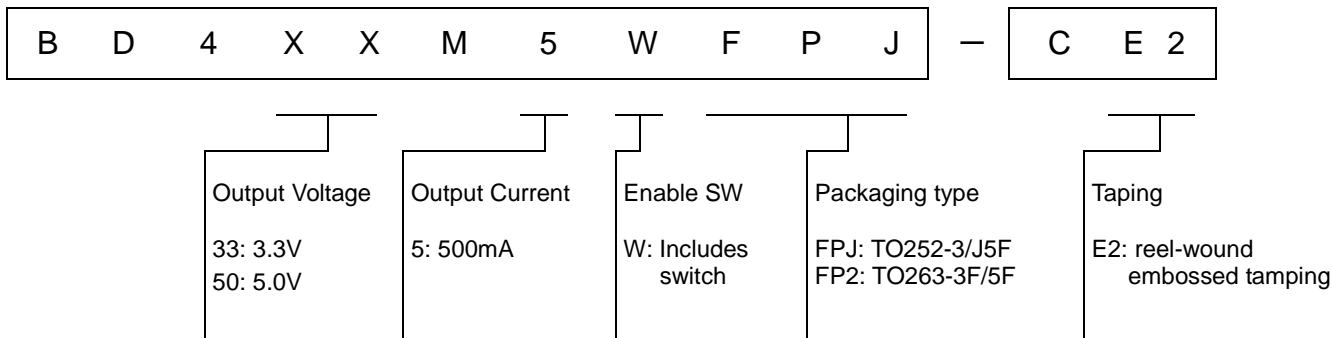

Figure 2. Typical Application Circuits

○Product structure : Silicon monolithic integrated circuit ○This product is not designed protection against radioactive rays.

※This document of ROHM may contain preliminary and is subject to change by ROHM without notice.

●Ordering Information



●Lineup

Output current ability	Output voltage (TYP.)	Enable SW *1	Package type	Orderable Part Number	Available (IC samples)
500mA	3.3V	○	TO252-J5F	BD433M5WFPJ-CE2	Developing
			TO263-5F	BD433M5WFP2-CE2	Developing
		×	TO252-3	BD433M5FP-CE2	Developing
			TO263-3F	BD433M5FP2-CE2	Developing
	5.0V	○	TO252-J5F	BD450M5WFPJ-CE2	Developing
			TO263-5F	BD450M5WFP2-CE2	Developing
		×	TO252-3	BD450M5FP-CE2	Developing
			TO263-3F	BD450M5FP2-CE2	Developing

*1 ○: Includes Enable switch
 ×: Not includes Enable switch

※This document of ROHM may contain preliminary and is subject to change by ROHM without notice.

●Pin Configuration

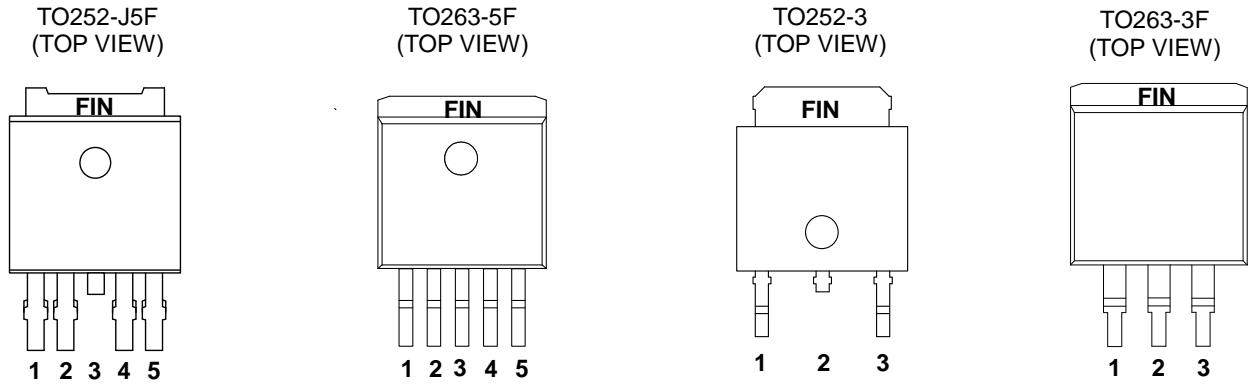

Figure 3. Pin Configuration

●Pin Description

■BD433/450M5WFPJ-C (TO252-J5F)

Pin No.	Pin Name	Function
1	VCC	Supply voltage input pin
2	CTL	Output Control Pin
3	GND	GND
4	N.C.	Not connected
5	VOUT	Output Pin
FIN	GND	GND

■BD433/450M5WFP2-C (TO263-5F)

Pin No.	Pin Name	Function
1	VCC	Supply voltage input pin
2	CTL	Output Control Pin
3	GND	GND
4	N.C.	Not connected
5	VOUT	Output Pin
FIN	GND	GND

(※N.C. Pin can be open or short with GND because it isn't connect it inside of IC.)

■BD433/450M5FP-C (TO252-3)

Pin No.	Pin Name	Function
1	VCC	Supply voltage input pin
2	N.C.	Not connected
3	VOUT	Output Pin
FIN	GND.	GND

■BD433/450M5FP2-C (TO263-3F)

Pin No.	Pin Name	Function
1	VCC	Supply voltage input pin
2	GND	GND
3	VOUT	Output Pin
FIN	GND	GND

(※N.C. Pin can be open or short with GND because it isn't connect it inside of IC.)

※This document of ROHM may contain preliminary and is subject to change by ROHM without notice.

●Block Diagram

■BD433/450M2WFPJ-C

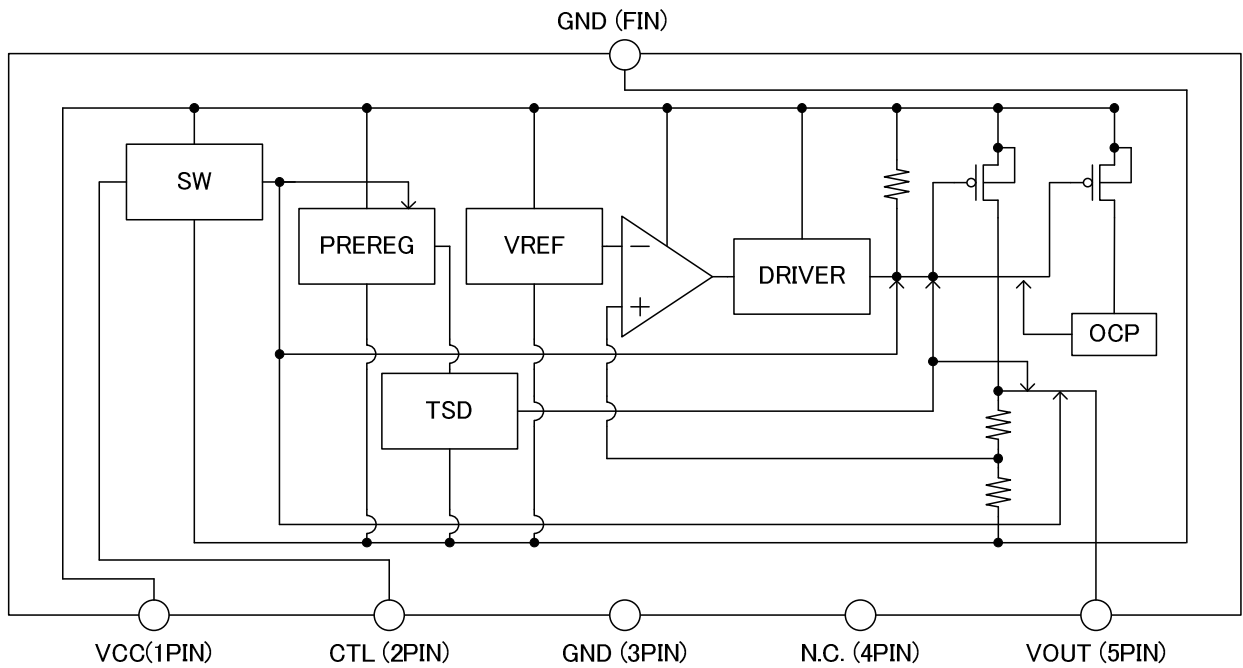

■BD433/450M5WFP2-C

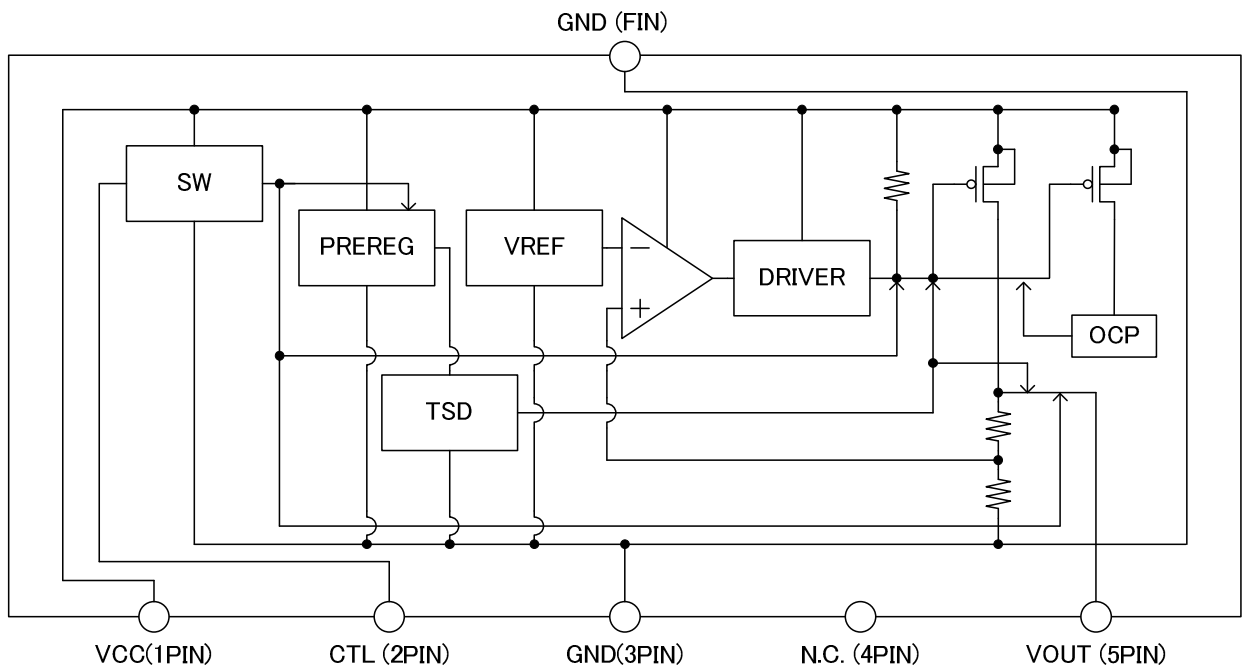

※This document of ROHM may contain preliminary and is subject to change by ROHM without notice.

■BD433/450M5FP-C

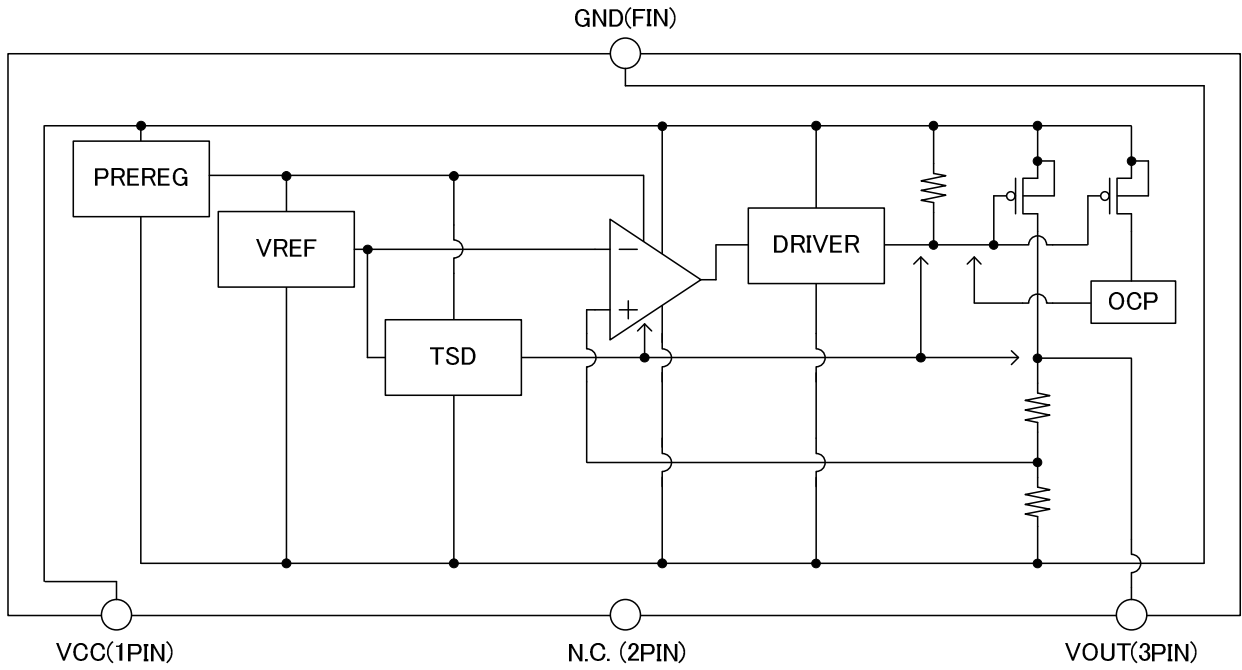

■BD433/450M5FP2-C

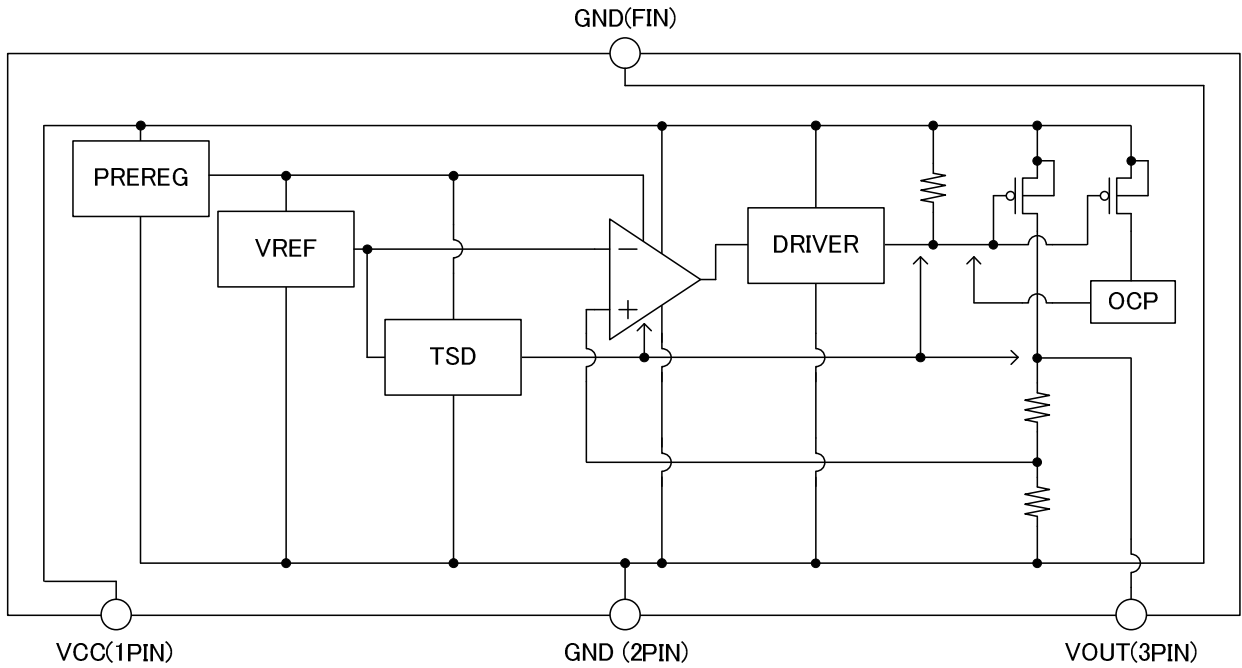

Figure 4. Block Diagram

※This document of ROHM may contain preliminary and is subject to change by ROHM without notice.

●Absolute Maximum Ratings

Parameter	Symbol	Ratings	Unit
Supply Voltage *1	VCC	-0.3 to +45.0	V
Output Control Voltage *2	CTL	-0.3 to +45.0	V
Output Voltage	VOUT	-0.3 to +7.0	V
Power Dissipation (TO252-J5F) *3	Pd	T.B.D	W
Power Dissipation (TO263-5F) *4	Pd	T.B.D	W
Power Dissipation (TO252-3) *5	Pd	1.2	W
Power Dissipation (TO263-3F) *6	Pd	T.B.D	W
Junction Temperature Range	Tj	-40 to +150	°C
Storage Temperature Range	Tstg	-55 to +150	°C
Maximum Junction Temperature	Tjmax	+150	°C

*1 Do not exceed Pd.

*2 Only includes Enable input

*3 TO252-J5F (Developing)

*4 TO263-5F (Developing)

*5 TO252-3 mounted on 70mm × 70mm × 1.6mm Glass-Epoxy PCB. If $T_a \geq 25^\circ\text{C}$, reduce by 9.6mW/°C

*6 TO263-3F (Developing)

●Operating Conditions (-40 < Tj < +125°C)

Parameter	Symbol	Min.	Max.	Unit
Supply Voltage *7	VCC	5.9	42.0	V
Supply Voltage *8	VCC	4.62	42.0	V
Output Control Voltage *9	CTL	0	42.0	V
Start-Up Voltage *10	VCC	3.0	-	V
Output Current	IOUT	0	500	mA

*7 BD450M5WFPJ-C / BD450M5WFP2-C / BD450M5FP-C / BD450M5FP2-C

*8 BD433M5WFPJ-C / BD433M5WFP2-C / BD433M5FP-C / BD433M5FP2-C

*9 Only includes Enable Input

*10 When IOUT=0mA

※This document of ROHM may contain preliminary and is subject to change by ROHM without notice.

●Electrical Characteristics

(Unless otherwise specified, $-40 < T_j < +125^{\circ}\text{C}$, $V_{CC}=13.5\text{V}$, $CTL=5\text{V}(*1)$, $I_{OUT}=0\text{mA}$)

Parameter	Symbol	Limit			Unit	Conditions
		Min.	Typ.	Max.		
Shut Down Current	Ishut	—	2.0	5.0	μA	$CTL=0\text{V}$ $T_j < 125^{\circ}\text{C}$
Bias Current	Ib	—	40	95	μA	$I_{OUT}=0\text{mA}$ $T_j < 125^{\circ}\text{C}$
		—	40	175	μA	$I_{OUT} < 500\text{mA}$ $T_j < 150^{\circ}\text{C}$
Output Voltage	VOUT (*2)	4.90	5.00	5.10	V	$6\text{V} < V_{CC} < 42\text{V}$, $0\text{mA} < I_{OUT} < 400\text{mA}$
		4.80	5.00	5.10	V	$6\text{V} < V_{CC} < 42\text{V}$ $400\text{mA} < I_{OUT} < 500\text{mA}$
	VOUT (*3)	3.23	3.30	3.37	V	$6\text{V} < V_{CC} < 42\text{V}$, $0\text{mA} < I_{OUT} < 400\text{mA}$
		3.20	3.30	3.37	V	$6\text{V} < V_{CC} < 42\text{V}$ $400\text{mA} < I_{OUT} < 500\text{mA}$
Dropout Voltage	ΔV_d (*2)	—	0.25	0.50	V	$V_{CC}=V_{OUT} \times 0.95$ (Typ.4.75V), $I_{OUT}=300\text{mA}$
	ΔV_d (*3)	—	0.38	0.75	V	$V_{CC}=V_{OUT} \times 0.95$ (Typ.3.135V), $I_{OUT}=300\text{mA}$
Ripple Rejection	R.R.	55	60	—	dB	$f=120\text{Hz}$, $e_{in}=1\text{V}_{rms}$, $I_{OUT}=100\text{mA}$
Line Regulation	Reg.I	—	10	30	mV	$V_{CC}=8\text{V} \rightarrow 16\text{V}$
Load Regulation	Reg.L	—	10	30	mV	$I_{OUT}=10\text{mA} \rightarrow 400\text{mA}$
Thermal Shut Down	TSD	—	175	—	$^{\circ}\text{C}$	T_j at TSD ON

*1 Only includes Enable input

*2 For BD450M5WFPJ-C / BD450M5WFP2-C / BD450M5FP-C / BD450M5FP2-C

*3 For BD433M5WFPJ-C / BD433M5WFP2-C / BD433M5FP-C / BD433M5FP2-C

●Electrical Characteristics (Enable function *4)

(Unless otherwise specified, $-40 < T_j < +125^{\circ}\text{C}$, $V_{CC}=13.5\text{V}$, $I_{OUT}=0\text{mA}$)

Parameter	Symbol	Limit			Unit	Conditions
		Min.	Typ.	Max.		
CTL ON Mode Voltage	VthH	2.8	—	—	V	ACTIVE MODE
CTL OFF Mode Voltage	VthL	—	—	0.8	V	OFF MODE
CTL Bias Current	ICTL	—	15	30	μA	$CTL=5\text{V}$

*4 For BD433M5WFPJ-C / BD433M5WFP2-C / BD450M5WFPJ-C / BD450M5WFP2-C

※This document of ROHM may contain preliminary and is subject to change by ROHM without notice.

●Application Examples

- Applying positive surge to the VCC pin

If the possibility exists that surges higher than 45V will be applied to the VCC pin, a zener diode should be placed between the VCC pin and GND pin as shown in the figure below.

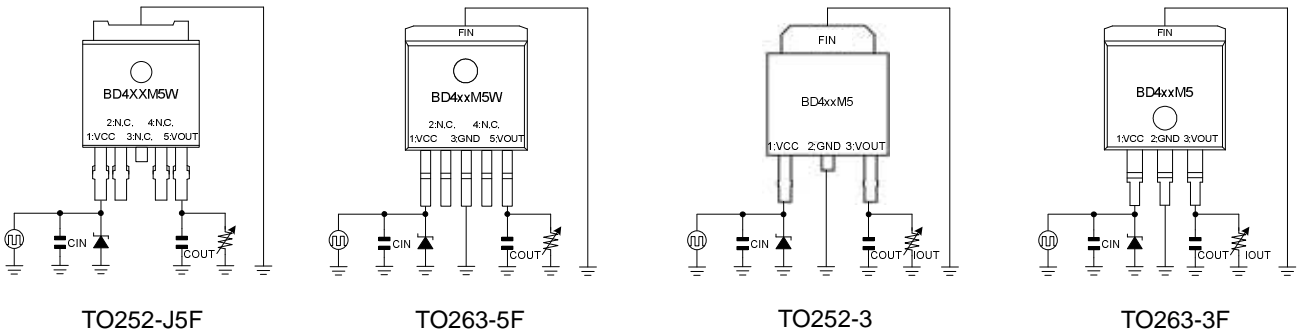

Figure 5. Sample Application Circuit 1

- Applying negative surge to the VCC pin

If the possibility exists that negative surges lower than the GND are applied to the VCC pin, a Shottky diode should be placed between the VCC pin and GND pin as shown in the figure below.

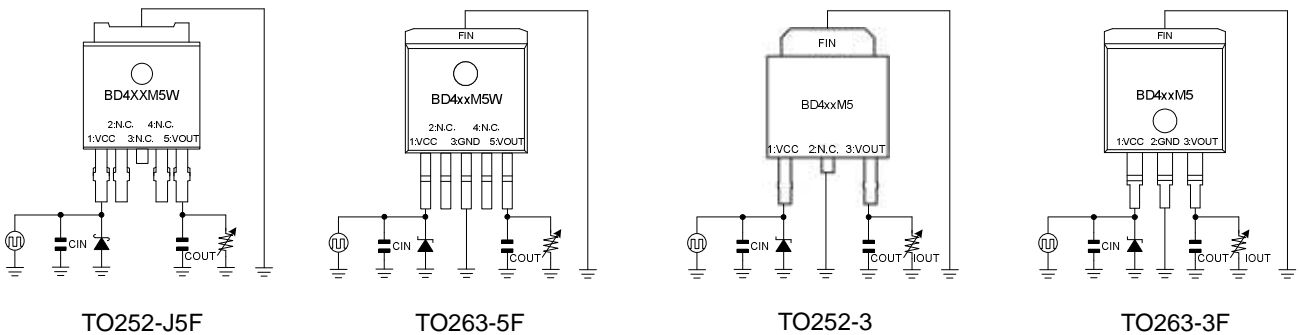

Figure 6. Sample Application Circuit 2

- Implementing a protection diode

If the possibility exists that a large inductive load is connected to the output pin resulting in back-EMF at time of startup and shutdown, a protection diode should be placed as shown in the figure below.

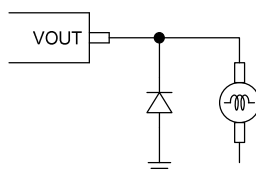

Figure 7. Sample Application Circuit 3

●I/O Equivalence Circuit

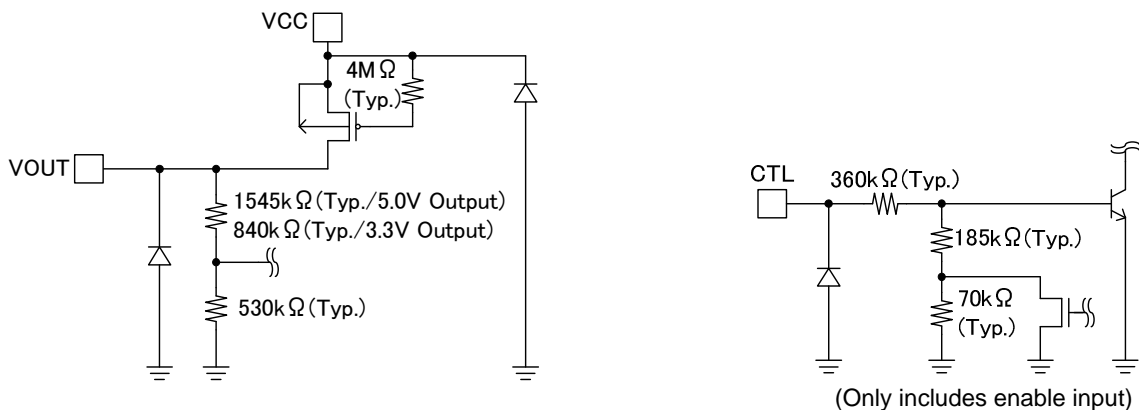

Figure 8. Input/Output Equivalence Circuit

※This document of ROHM may contain preliminary and is subject to change by ROHM without notice.

●Operational Notes

1) Absolute maximum ratings

Exceeding the absolute maximum rating for supply voltage, operating temperature or other parameters can result in damages to or destruction of the chip. In this event it also becomes impossible to determine the cause of the damage (e.g. short circuit, open circuit, etc). Therefore, if any special mode is being considered with values expected to exceed the absolute maximum ratings, implementing physical safety measures, such as adding fuses, should be considered.

2) The electrical characteristics given in this specification may be influenced by conditions such as temperature, supply voltage and external components. Transient characteristics should be sufficiently verified.

3) GND electric potential

Keep the GND pin potential at the lowest (minimum) level under any operating condition. Furthermore, ensure that, including the transient, none of the pin's voltages are less than the GND pin voltage.

4) GND wiring pattern

When both a small-signal GND and a high current GND are present, single-point grounding (at the set standard point) is recommended. This in order to separate the small-signal and high current patterns and to ensure that voltage changes stemming from the wiring resistance and high current do not cause any voltage change in the small-signal GND. Similarly, care must be taken to avoid wiring pattern fluctuations in any connected external component GND.

5) Inter-pin shorting and mounting errors

Ensure that when mounting the IC on the PCB the direction and position are correct. Incorrect mounting may result in damaging the IC. Also, shorts caused by dust entering between the output, input and GND pin may result in damaging the IC.

6) Inspection using the set board

The IC needs to be discharged after each inspection process as, while using the set board for inspection, connecting a capacitor to a low-impedance pin may cause stress to the IC. As a protection from static electricity, ensure that the assembly setup is grounded and take sufficient caution with transportation and storage. Also, make sure to turn off the power supply when connecting and disconnecting the inspection equipment.

7) Power dissipation (Pd)

Should by any chance the power dissipation rating be exceeded the rise in temperature of the chip may result in deterioration of the properties of the chip. The absolute maximum rating of the Pd stated in this specification is when the IC is mounted on a 70mm X 70mm X 1.6mm glass epoxy board. In case of exceeding this absolute maximum rating, increase the board size and copper area to prevent exceeding the Pd rating.

8) Thermal design

The power dissipation under actual operating conditions should be taken into consideration and a sufficient margin should be allowed for in the thermal design. On the reverse side of the package this product has an exposed heat pad for improving the heat dissipation. Use both the front and reverse side of the PCB to increase the heat dissipation pattern as far as possible. The amount of heat generated depends on the voltage difference across the input and output, load current, and bias current. Therefore, when actually using the chip, ensure that the generated heat does not exceed the Pd rating.

(Tjmax: maximum junction temperature=150°C, Ta: ambient temperature (°C), θja: junction-to-ambient thermal resistance (°C/W), Pd: power dissipation rating (W), Pc: power consumption (W), VCC: input voltage, VOUT: output voltage, IOOUT: load current, Ib: bias current)

Power dissipation rating
Power consumption

$$Pd (W) = (T_{jmax} - T_a) / \theta_{ja}$$

$$Pc (W) = (VCC - VOUT) \times IOOUT + VCC \times Ib$$

※This document of ROHM may contain preliminary and is subject to change by ROHM without notice.

9) Rapid variation in VCC voltage and load current

In case of a rapidly changing input voltage, transients in the output voltage might occur due to the use of a MOSFET as output transistor. Although the actual application might be the cause of the transients, the IC input voltage, output current and temperature are also possible causes. In case problems arise within the actual operating range, use countermeasures such as adjusting the output capacitance.

10) Minute variation in output voltage

In case of using an application susceptible to minute changes to the output voltage due to noise, changes in input and load current, etc., use countermeasures such as implementing filters.

11) Overcurrent protection circuit

This IC incorporates an integrated overcurrent protection circuit that is activated when the load is shorted. This protection circuit is effective in preventing damage due to sudden and unexpected incidents. However, the IC should not be used in applications characterized by continuous operation or transitioning of the protection circuit.

12) Thermal shutdown (TSD)

This IC incorporates an integrated thermal shutdown circuit to prevent heat damage to the IC. Normal operation should be within the power dissipation rating, if however the rating is exceeded for a continued period, the junction temperature (T_j) will rise and the TSD circuit will be activated and turn all output pins OFF. After the T_j falls below the TSD threshold the circuits are automatically restored to normal operation.

Note that the TSD circuit operates in a situation that exceeds the absolute maximum ratings and therefore, under no circumstances, should the TSD circuit be used in a set design or for any purpose other than protecting the IC from heat damage.

13) In some applications, the VCC and pin potential might be reversed, possibly resulting in circuit internal damage or damage to the elements. For example, while the external capacitor is charged, the VCC shorts to the GND. Use a capacitor with a capacitance with less than 1000 μ F. We also recommend using reverse polarity diodes in series or a bypass between all pins and the VCC pin.

14) This monolithic IC contains P+ isolation and P substrate layers between adjacent elements in order to keep them isolated. P/N junctions are formed at the intersection of these P layers with the N layers of other elements to create a variety of parasitic elements.

For example, in case a resistor and a transistor are connected to the pins as shown in the figure below then:

- The P/N junction functions as a parasitic diode when GND > pin A for the resistor, or GND > pin B for the transistor.
- Also, when GND > pin B for the transistor (NPN), the parasitic diode described above combines with the N layer of the other adjacent elements to operate as a parasitic NPN transistor.

Parasitic diodes inevitably occur in the structure of the IC. Their operation can result in mutual interference between circuits and can cause malfunctions and, in turn, physical damage to or destruction of the chip. Therefore do not employ any method in which parasitic diodes can operate such as applying a voltage to an input pin that is lower than the (P substrate) GND.

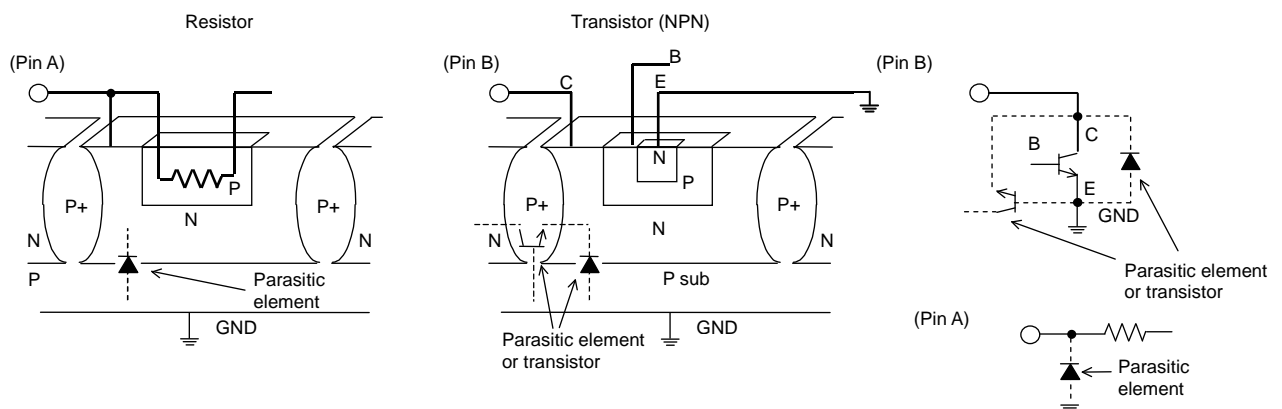

Figure 9.

※This document of ROHM may contain preliminary and is subject to change by ROHM without notice.

Status of this document

The Japanese version of this document is formal specification. A customer may use this translation version only for a reference to help reading the formal version.

If there are any differences in translation version of this document formal version takes priority

Application example

- ROHM cannot provide adequate confirmation of patents.
 - The product described in this specification is designed to be used with ordinary electronic equipment or devices (such as audio-visual equipment, office-automation equipment, communications devices, electrical appliances, and electronic toys).
- Should you intend to use this product with equipment or devices which require an extremely high level of reliability and the malfunction of which would directly endanger human life (such as medical instruments, transportation equipment, aerospace machinery, nuclear-reactor controllers, fuel controllers and other safety devices), please be sure to consult with our sales representative in advance.
- ROHM assumes no responsibility for the use of any circuits described herein, conveys no license under any patent or other right, and makes no representations that the circuits are free from patent infringement.

※This document of ROHM may contain preliminary and is subject to change by ROHM without notice.

●Marking Diagrams (TOP VIEW)

TO252-J5F

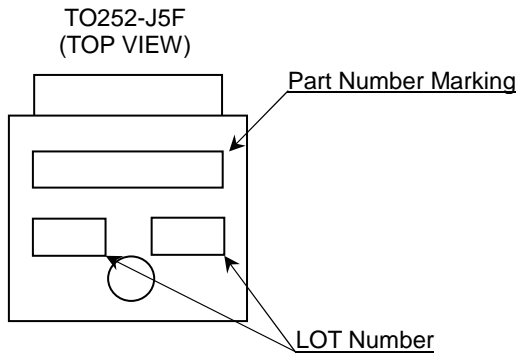

Part Number Marking	Output Voltage [V]	Enable input
BD433M5W	3.3	○
BD450M5W	5.0	○

*1 ○ : Includes Enable switch
 × : Not includes Enable switch

TO263-5F

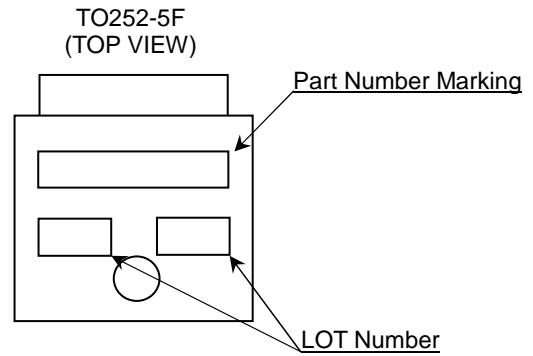

Part Number Marking	Output Voltage [V]	Enable input
BD433M5W	3.3	○
BD450M5W	5.0	○

*1 ○ : Includes Enable switch
 × : Not includes Enable switch

TO252-3

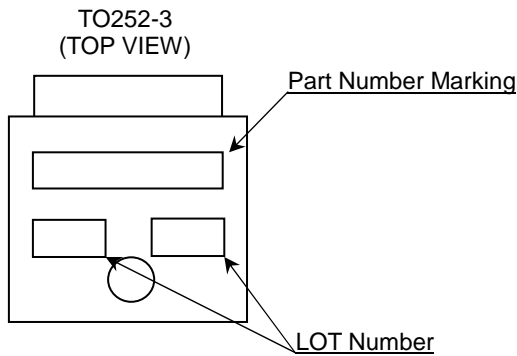

Part Number Marking	Output Voltage [V]	Enable input
BD433M5	3.3	○
BD450M5	5.0	○

*1 ○ : Includes Enable switch
 × : Not includes Enable switch

TO263-3F

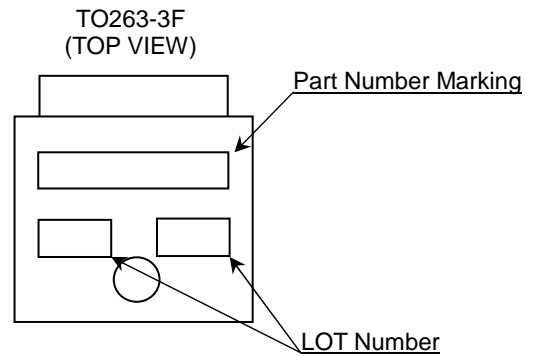

Part Number Marking	Output Voltage [V]	Enable input
BD433M5	3.3	○
BD450M5	5.0	○

*1 ○ : Includes Enable switch
 × : Not includes Enable switch

●Revision History

※This document of ROHM may contain preliminary and is subject to change by ROHM without notice.

Date	Revision	Changes
18.Oct.2012	001	Pre- Release

※This document of ROHM may contain preliminary and is subject to change by ROHM without notice.

Notice

●General Precaution

- 1) Before you use our Products, you are requested to carefully read this document and fully understand its contents. ROHM shall not be in any way responsible or liable for failure, malfunction or accident arising from the use of any ROHM's Products against warning, caution or note contained in this document.
- 2) All information contained in this document is current as of the issuing date and subject to change without any prior notice. Before purchasing or using ROHM's Products, please confirm the latest information with a ROHM sales representative.

●Precaution on using ROHM Products

- 1) Our Products are designed and manufactured for application in ordinary electronic equipments (such as AV equipment, OA equipment, telecommunication equipment, home electronic appliances, amusement equipment, etc.). If you intend to use our Products in devices requiring extremely high reliability (such as medical equipment, transport equipment, traffic equipment, aircraft/spacecraft, nuclear power controllers, fuel controllers, car equipment including car accessories, safety devices, etc.) and whose malfunction or failure may cause loss of human life, bodily injury or serious damage to property ("Specific Applications"), please consult with the ROHM sales representative in advance. Unless otherwise agreed in writing by ROHM in advance, ROHM shall not be in any way responsible or liable for any damages, expenses or losses incurred by you or third parties arising from the use of any ROHM's Products for Specific Applications.
- 2) ROHM designs and manufactures its Products subject to strict quality control system. However, semiconductor products can fail or malfunction at a certain rate. Please be sure to implement, at your own responsibilities, adequate safety measures including but not limited to fail-safe design against the physical injury, damage to any property, which a failure or malfunction of our Products may cause. The following are examples of safety measures:
 - [a] Installation of protection circuits or other protective devices to improve system safety
 - [b] Installation of redundant circuits to reduce the impact of single or multiple circuit failure
- 3) Our Products are designed and manufactured for use under standard conditions and not under any special or extraordinary environments or conditions, as exemplified below. Accordingly, ROHM shall not be in any way responsible or liable for any damages, expenses or losses arising from the use of any ROHM's Products under any special or extraordinary environments or conditions. If you intend to use our Products under any special or extraordinary environments or conditions (as exemplified below), your independent verification and confirmation of product performance, reliability, etc. prior to use, must be necessary:
 - [a] Use of our Products in any types of liquid, including water, oils, chemicals, and organic solvents
 - [b] Use of our Products outdoors or in places where the Products are exposed to direct sunlight or dust
 - [c] Use of our Products in places where the Products are exposed to sea wind or corrosive gases, including Cl₂, H₂S, NH₃, SO₂, and NO₂
 - [d] Use of our Products in places where the Products are exposed to static electricity or electromagnetic waves
 - [e] Use of our Products in proximity to heat-producing components, plastic cords, or other flammable items
 - [f] Sealing or coating our Products with resin or other coating materials
 - [g] Use of our Products without cleaning residue of flux (even if you use no-clean type fluxes, cleaning residue of flux is recommended); or Washing our Products by using water or water-soluble cleaning agents for cleaning residue after soldering
 - [h] Use of the Products in places subject to dew condensation
- 4) The Products are not subject to radiation-proof design.
- 5) Please verify and confirm characteristics of the final or mounted products in using the Products.
- 6) In particular, if a transient load (a large amount of load applied in a short period of time, such as pulse) is applied, confirmation of performance characteristics after on-board mounting is strongly recommended. Avoid applying power exceeding normal rated power; exceeding the power rating under steady-state loading condition may negatively affect product performance and reliability.
- 7) De-rate Power Dissipation (Pd) depending on Ambient temperature (Ta). When used in sealed area, confirm the actual ambient temperature.
- 8) Confirm that operation temperature is within the specified range described in the product specification.
- 9) ROHM shall not be in any way responsible or liable for failure induced under deviant condition from what is defined in this document.

● **Precaution for Mounting / Circuit board design**

- 1) When a highly active halogenous (chlorine, bromine, etc.) flux is used, the residue of flux may negatively affect product performance and reliability.
- 2) In principle, the reflow soldering method must be used; if flow soldering method is preferred, please consult with the ROHM representative in advance.

For details, please refer to ROHM Mounting specification

● **Precautions Regarding Application Examples and External Circuits**

- 1) If change is made to the constant of an external circuit, please allow a sufficient margin considering variations of the characteristics of the Products and external components, including transient characteristics, as well as static characteristics.
- 2) You agree that application notes, reference designs, and associated data and information contained in this document are presented only as guidance for Products use. Therefore, in case you use such information, you are solely responsible for it and you must exercise your own independent verification and judgment in the use of such information contained in this document. ROHM shall not be in any way responsible or liable for any damages, expenses or losses incurred by you or third parties arising from the use of such information.

● **Precaution for Electrostatic**

This Product is electrostatic sensitive product, which may be damaged due to electrostatic discharge. Please take proper caution in your manufacturing process and storage so that voltage exceeding the Products maximum rating will not be applied to Products. Please take special care under dry condition (e.g. Grounding of human body / equipment / solder iron, isolation from charged objects, setting of Ionizer, friction prevention and temperature / humidity control).

● **Precaution for Storage / Transportation**

- 1) Product performance and soldered connections may deteriorate if the Products are stored in the places where:
 - [a] the Products are exposed to sea winds or corrosive gases, including Cl₂, H₂S, NH₃, SO₂, and NO₂
 - [b] the temperature or humidity exceeds those recommended by ROHM
 - [c] the Products are exposed to direct sunshine or condensation
 - [d] the Products are exposed to high Electrostatic
- 2) Even under ROHM recommended storage condition, solderability of products out of recommended storage time period may be degraded. It is strongly recommended to confirm solderability before using Products of which storage time is exceeding the recommended storage time period.
- 3) Store / transport cartons in the correct direction, which is indicated on a carton with a symbol. Otherwise bent leads may occur due to excessive stress applied when dropping of a carton.
- 4) Use Products within the specified time after opening a humidity barrier bag. Baking is required before using Products of which storage time is exceeding the recommended storage time period.

● **Precaution for Product Label**

QR code printed on ROHM Products label is for ROHM's internal use only.

● **Precaution for Disposition**

When disposing Products please dispose them properly using an authorized industry waste company.

● **Precaution for Foreign Exchange and Foreign Trade act**

Since our Products might fall under controlled goods prescribed by the applicable foreign exchange and foreign trade act, please consult with ROHM representative in case of export.

● **Precaution Regarding Intellectual Property Rights**

- 1) All information and data including but not limited to application example contained in this document is for reference only. ROHM does not warrant that foregoing information or data will not infringe any intellectual property rights or any other rights of any third party regarding such information or data. ROHM shall not be in any way responsible or liable for infringement of any intellectual property rights or other damages arising from use of such information or data.:
- 2) No license, expressly or implied, is granted hereby under any intellectual property rights or other rights of ROHM or any third parties with respect to the information contained in this document.

●Other Precaution

- 1) The information contained in this document is provided on an "as is" basis and ROHM does not warrant that all information contained in this document is accurate and/or error-free. ROHM shall not be in any way responsible or liable for any damages, expenses or losses incurred by you or third parties resulting from inaccuracy or errors of or concerning such information.
- 2) This document may not be reprinted or reproduced, in whole or in part, without prior written consent of ROHM.
- 3) The Products may not be disassembled, converted, modified, reproduced or otherwise changed without prior written consent of ROHM.
- 4) In no event shall you use in any way whatsoever the Products and the related technical information contained in the Products or this document for any military purposes, including but not limited to, the development of mass-destruction weapons.
- 5) The proper names of companies or products described in this document are trademarks or registered trademarks of ROHM, its affiliated companies or third parties.